



LAYOUT DIAGRAM (原理圖) : (FIG-1)

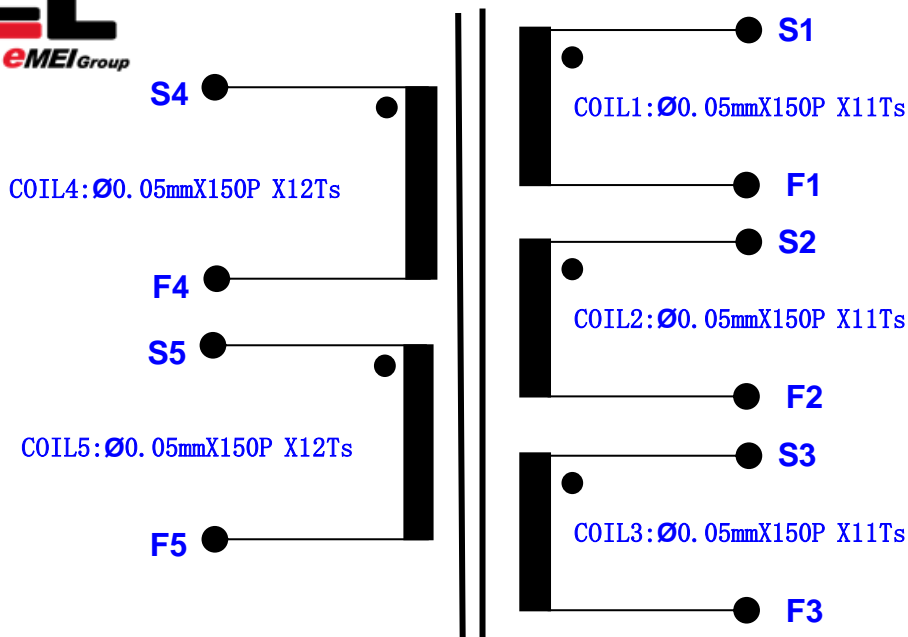

FIG-1

CHECKING SPECIFICATION(特性要求) : (Table-1)

ITEM 項目	MEASUREMENTS 测试脚位	CHARACTERISTIC S 测试範圍	MEASURING CONDITIONS 测试條件 T(°C)=25± 3; HR(%)=45± 15	REMARK 備注
LS 电感	PIN(S1-F1) PIN(S2-F2) PIN(S3-F3) PIN(S4-F4) PIN(S5-F5)	15.0uH+/-10%	F(kHz) =100 Ug(V) =1	SERIAL MODE 串联模式
DCR 直流电阻	PIN(S1-F1) PIN(S2-F2) PIN(S3-F3)	100+/-10mΩ	25°C	4 WIRE MODE 四线模式
DCR 直流电阻	PIN(S4-F4) PIN(S5-F5)	110+/-10mΩ	25°C	4 WIRE MODE 四线模式
PH 相位	REFER TO LAYOUT DIAGRAM FIG-1 参考原理图 (FIG-1)			

REMARK:

100% testing for the above electrical characteristics.

所有产品按以上要求进行100%测试.

Quality Requirement:(品质要求)

Ref ANSI/ASQC.Z1.4 2008 Level II . Major AQL=0.4% Minor AQL=1.0%.

参照ANSI/ASQC.Z1.4 2008 Level II . Major AQL=0.4% Minor AQL=1.0%.

Prepared By:	DATE :	TITLE: Choke	CUSTOMER	MODEL NO:AC126X66P	
Checked By:	DATE :		Approved:	REV.	00
Approved By:	DATE :		Date:	PAGE 1 OF 2	

UNIT : mm

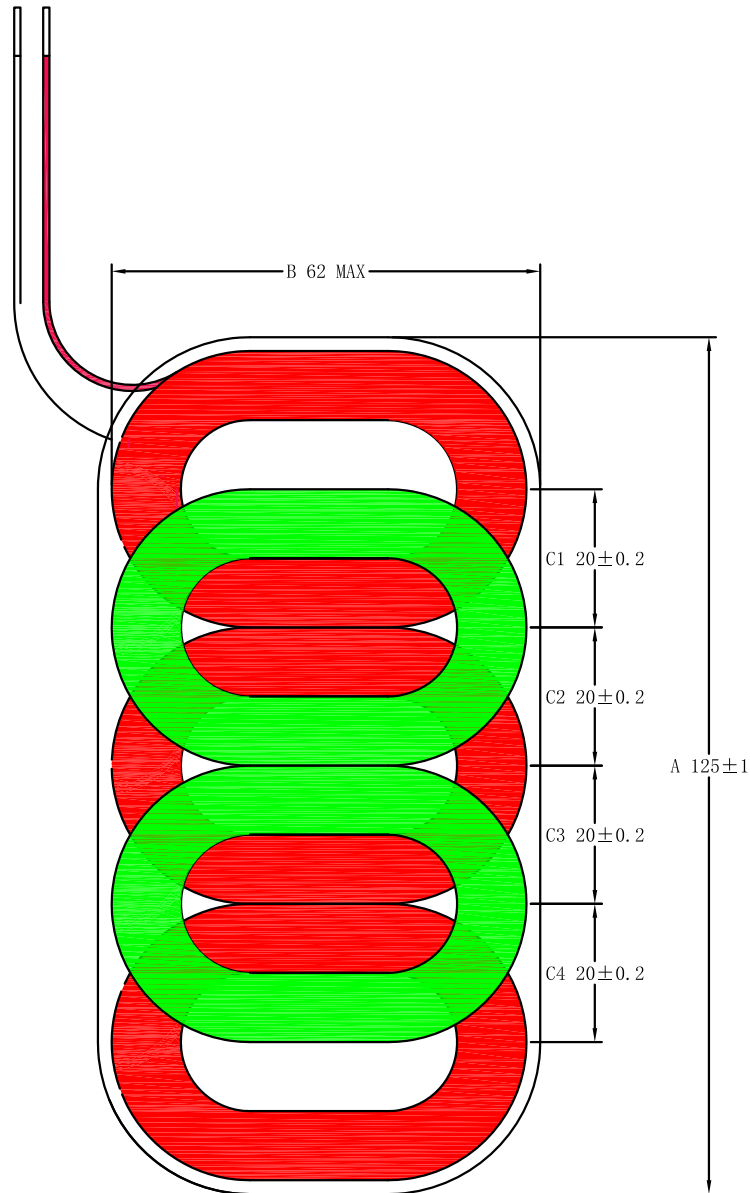

NOTES:

FIG-2

1. GREEN COILS: 12 TURNS
绿色标示的线圈: 12圈
2. RED COILS: 11 TURNS
红色标示的线圈: 11圈
3. The part must be complied with RoHS
产品需满足RoHS要求

Prepared By :	Date:	TITLE:	CUSTOMER	MODEL NO.: AC126X66	
Checked By :	Date:	CHOKE	Approved:	Rev.:	00
Approved By :	Date:		Date:	PAGE 2 OF 2	

免责声明

Disclaimer

Specifications and appearances may change without notice. All statements, technical information and recommendations herein are based on tests that we believed to be reliable, but the accuracy and completeness are not guaranteed. Before using, user should determine the suitability of the product for its intended use, and the user assumes all risks and liabilities whatsoever in connection therewith. Neither the seller nor the manufacturer shall be liable for any loss or damage, direct, incidental or consequential, including loss of profits or revenues arising from the use or inability to use the product. Any statements or recommendations shall have no effect unless contained in an agreement signed by authorized personnel of the seller and manufacturer.

依美电感保留更改产品资料和外观的最终权利而无需事先通知。如有任何争议，依美电感保留最终决定权。此中文免责声明为英文版本译本，如中、英文两个版本有任何抵触或不相符之处，应以英文版本为准。