

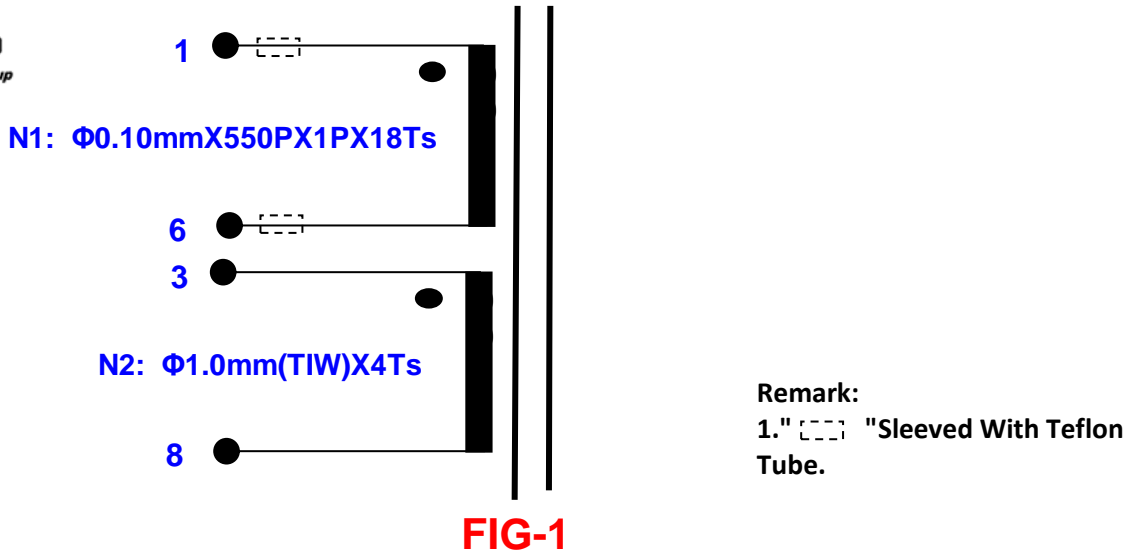

LAYOUT DIAGRAM(原理圖): (FIG-1)



DATA SPECIFICATION特性要求: (Table-1)

ITEM 项目	MEASUREMENT S 测试脚位	CHARACTERISTICS 测试范围	MEASURING CONDITIONS 测试条件 ($T=20\pm 4^{\circ}\text{C}$; $\text{HR}(\%)=45\pm 15$)	REMARK 备注
LS 电感	PIN(1-6)	$19.5\mu\text{H} \pm 15\%$	F(kHz)=10 $U_g(\text{V})=0.1$	SERIAL MODE 串联模式
DCR 直流电阻	PIN(1-6)	$7.0\text{m}\Omega \text{ MAX}$	20°C	4 WIRES MODE 四线模式
TURN RATIO 圈数比	PIN(1-6):PIN(3-8)	$18\text{Ts}:4\text{Ts} \pm 0.5\text{Ts}$	F(kHz)=20 $U_g(\text{V})=1.0$	/
PH 相位	REFER TO LAYOUT DIAGRAM FIG-1 参照原理图 FIG-1			

REMARK:初级和次级不相同的两个绕组需测试是否短路

100% testing for the above electrical characteristics.
所有产品按以上要求进行100%测试.

Quality Requirement:(品质要求)

Ref ANSI/ASQC.Z1.4 2008 Level II . Major AQL=0.4% Minor AQL=1.0%.
参照ANSI/ASQC.Z1.4 2008 Level II . Major AQL=0.4% Minor AQL=1.0%.

Prepared By:	DATE :	TITLE: CHOKE	CUSTOMER	MODEL NO.:TBP4U18	
Checked By :	DATE :		Approved:	REV.	00
Approved By :	DATE :		Date:	PAGE 1 OF 2	

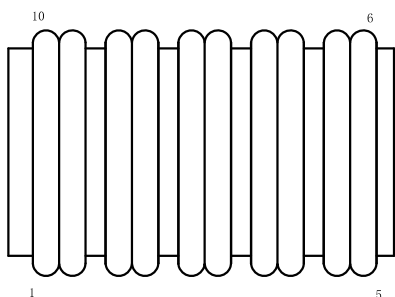

FIG-2

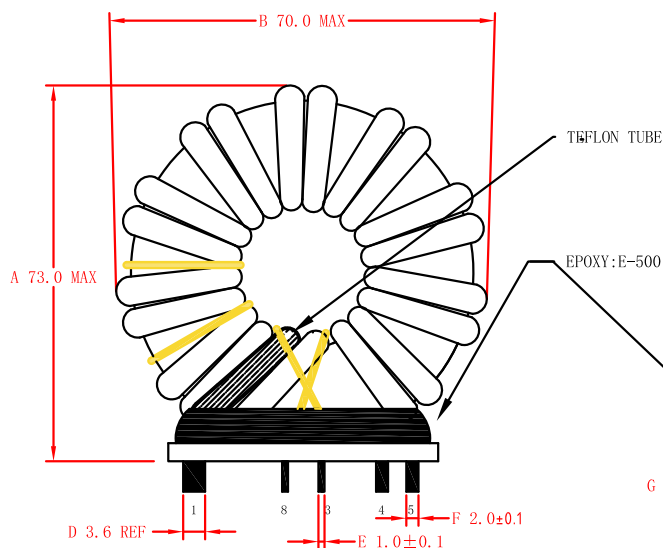

FIG-3

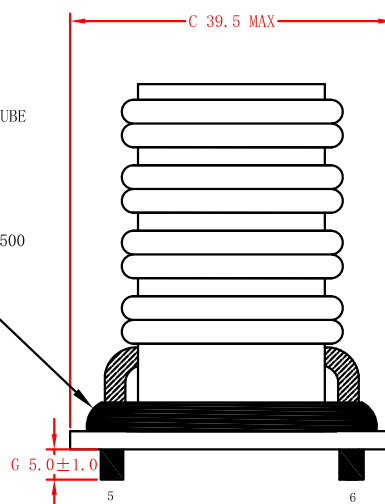

FIG-4

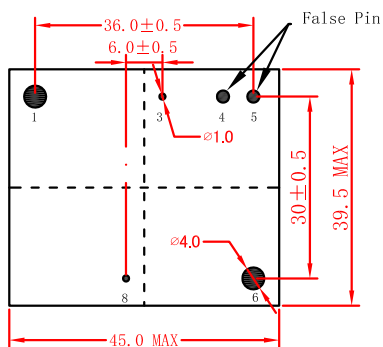

FIG-5

NOTES:

1. A teflon tube should be added at the beginning and end
起尾线需加铁氟龙套管
2. The product should be according to RoHS
产品要符合RoHS
3. Fixed magnetic ring and PCB board with E-500 glue
用E-500胶水点胶固定磁环与PCB板
4. Products need to be impregnated with varnish and vacuumed
产品需浸凡立水且抽真空

Prepared By :	Date :	TITLE : CHOKE	CUSTOMER	MODEL NO. :TBP4U18	
Checked By :	Date :		Approved:	REV.	00
Approved By :	Date :		Date:	PAGE 1 OF 2	

免责声明
Disclaimer

Specifications and appearances may change without notice. All statements, technical information and recommendations herein are based on tests that we believed to be reliable, but the accuracy and completeness are not guaranteed. Before using, user should determine the suitability of the product for its intended use, and the user assumes all risks and liabilities whatsoever in connection therewith. Neither the seller nor the manufacturer shall be liable for any loss or damage, direct, incidental or consequential, including loss of profits or revenues arising from the use or inability to use the product. Any statements or recommendations shall have no effect unless contained in an agreement signed by authorized personnel of the seller and manufacturer.

依美电感保留更改产品资料和外观的最终权利而无需事先通知。如有任何争议，依美电感保留最终决定权。此中文免责声明为英文版本译本，如中、英文两个版本有任何抵触或不相符之处，应以英文版本为准。