



DATA SPECIFICATION (特性要求) : (Table-1)

ITEM 項目	MEASUREMENTS 测试脚位	CHARACTERISTICS 测试范围	MEASURING CONDITIONS 测试条件 T(°C)=25; HR(%)=45±15	REMARK 备注
LS 电感	PIN(8-2)	600uH MIN.	F(KHz) =100 Ug(V) =0.3	SERIAL MODE 串联模式
	PIN(3-10)	600uH MIN.	F(KHz) =100 Ug(V) =0.3	SERIAL MODE 串联模式
	PIN(A-B)	80uH MIN.	F(KHz) =100 Ug(V) =0.3	SERIAL MODE 串联模式
DCR 电阻	PIN(8-2)	39mΩ ±35%		4 WIRE MODE 四线模式
	PIN(3-10)	26mΩ ±35%		4 WIRE MODE 四线模式
	PIN(A-B)	1.0mΩ ~3.0mΩ		4 WIRE MODE 四线模式
TR 圈比	(10-8)/(8-2)/(3-10)/(A-B)	34:17:17:6 ±0.3TS	F(KHz) =50 Ug(V) =1 SHORTED PIN2&PIN3	APPLY Ug(10-8) 電 壓施加于(10-8)
HIPOT 耐压	PRI./SEC.	NO BREAKDOWN 漏电流 ≤5.0mA	VAC=4000V /3SEC.	50Hz/60Hz
	PRI./CORE	NO BREAKDOWN 漏电流 ≤5.0mA	VAC=4000V /3SEC.	50Hz/60Hz
	SEC./CORE	NO BREAKDOWN 漏电流 ≤5.0mA	VAC=2000V /3SEC.	50Hz/60Hz
IR 绝缘 电阻	PRI./SEC.	100MΩ MIN.	VDC=500V	
	PRI./CORE	100MΩ MIN.	VDC=500V	
	SEC./CORE	100MΩ MIN.	VDC=500V	
PH 相位	REFER TO LAYOUT DIAGRAM (FIG-1) 参考原理图 (FIG-1)			

Prepared By ENG:	DATE:	TITLE: TRANSFORMER	CUSTOMER	MODEL NO:ETD49	
Checked By QA:	DATE:		Approved:	REV.	00
Approved By ENG:	DATE:		Date:	PAGE 1 OF 4	



OUTLINE DIAGRAM(外观图):

UNIT : mm

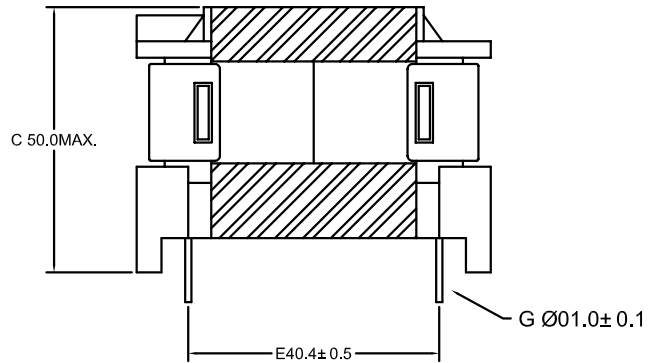
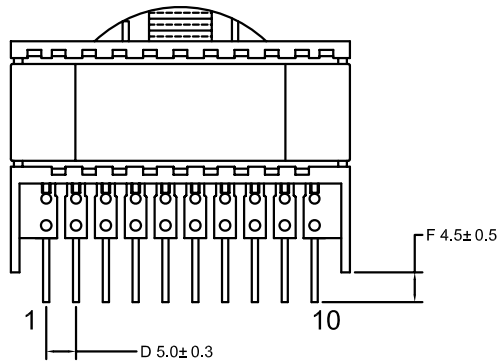
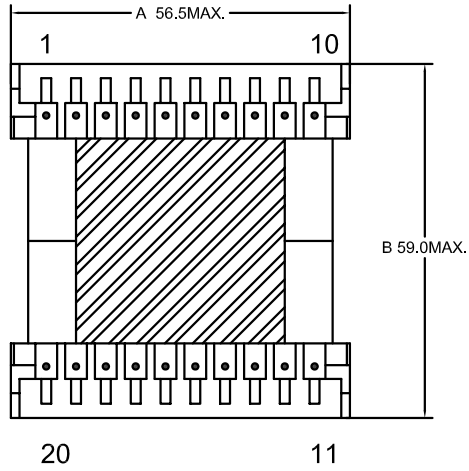

NOTES:

1. The core are to be held with 3 layers 15.0mm width tape;
在铁芯上包3 圈15.0mm宽的胶纸;
2. The product must be impregnated varnish #642 .
产品须含浸凡立水#642.
3. YYWW:year week code.
YYWW:表示年份 周期代码.
4. The part should be compied with RoHS.
产品应符合ROHS要求.

Prepared By ENG:	Date :	TITLE : TRANSFORMER	CUSTOMER Approved: Date:	MODEL NO. :ETD49	
Checked By QA:	Date :			REV. :	00
Approved By ENG:	Date :			PAGE 2 OF 4	



LAYOUT DIAGRAM (原理圖) : (FIG-1)

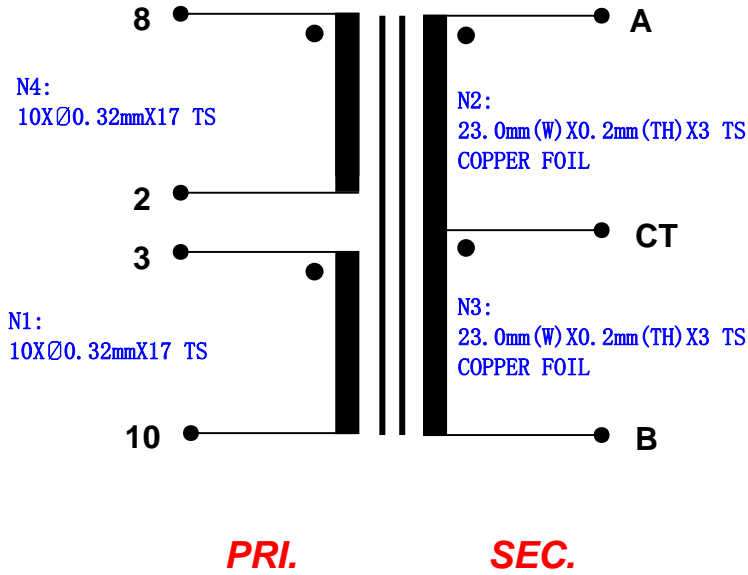

FIG-1

Prepared By ENG:	DATE:	TITLE: TRANSFORMER	CUSTOMER	MODEL NO:ETD49	
Checked By QA:	DATE:		Approved:	REV.	00
Approved By ENG:	DATE:		Date:	PAGE 3 OF 4	



CROSS SECTION DIAGRAM(剖视图): (FIG-2)

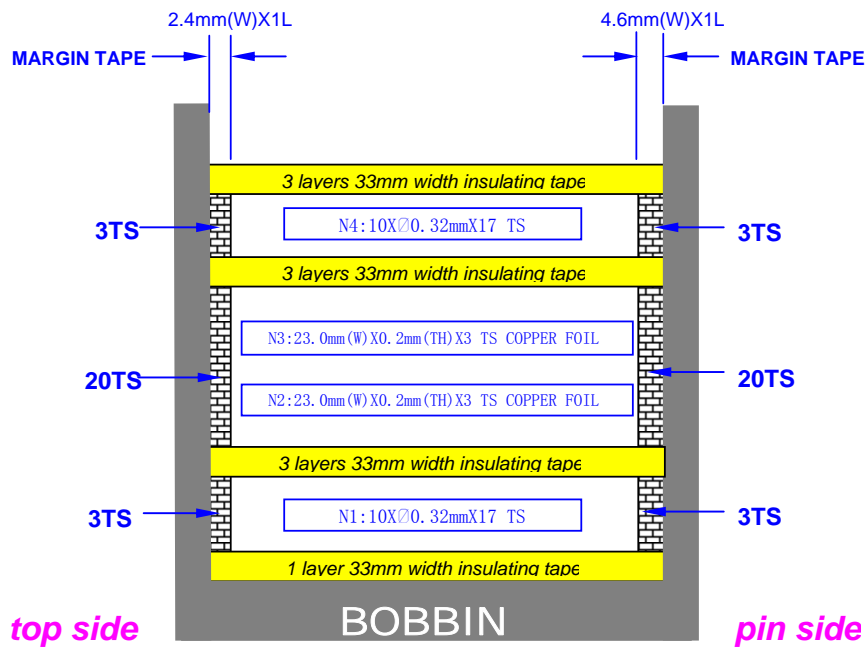
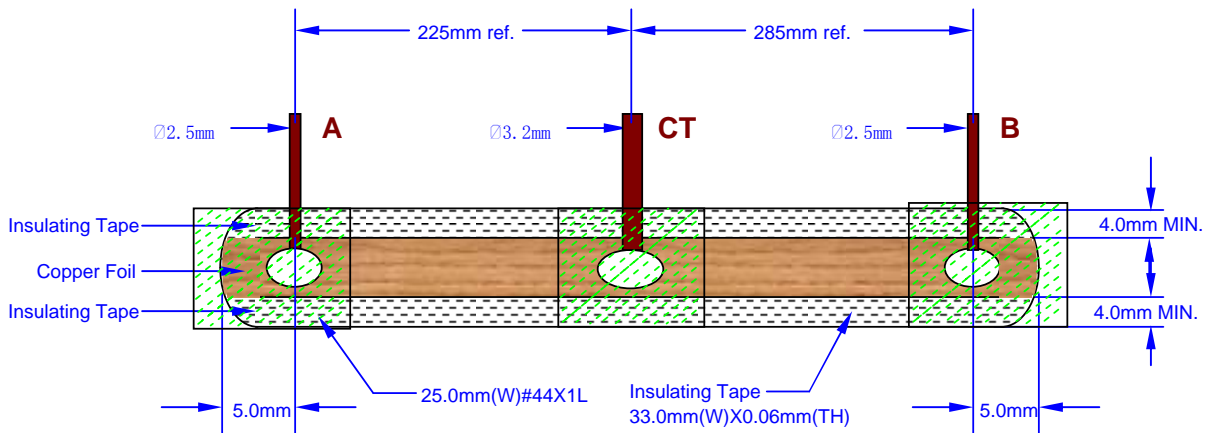

FIG-2

NOTE:Copper Foil

1. 23.0mm(W)X0.2mm(TH)X510mm(L):



Prepared By ENG:	DATE:	TITLE: TRANSFORMER	CUSTOMER	MODEL NO:ETD49	
Checked By QA:	DATE:		Approved:	REV.	00
Approved By ENG:	DATE:		Date:	PAGE 4 OF 4	

**免责声明
Disclaimer**

Specifications and appearances may change without notice. All statements, technical information and recommendations herein are based on tests that we believed to be reliable, but the accuracy and completeness are not guaranteed. Before using, user should determine the suitability of the product for its intended use, and the user assumes all risks and liabilities whatsoever in connection therewith. Neither the seller nor the manufacturer shall be liable for any loss or damage, direct, incidental or consequential, including loss of profits or revenues arising from the use or inability to use the product. Any statements or recommendations shall have no effect unless contained in an agreement signed by authorized personnel of the seller and manufacturer.

依美电感保留更改产品资料和外观的最终权利而无需事先通知。如有任何争议，依美电感保留最终决定权。此中文免责声明为英文版本译本，如中、英文两个版本有任何抵触或不相符之处，应以英文版本为准。