



Data Specification(特 性 要 求) : (Table-1)

ITEM 項目	MEASUREMENTS 测试脚位	CHARACTERISTICS 测试範圍	MEASURING CONDITIONS 測試條件 T(°C)=25±3;HR(%)=45±15	REMARK 備注
LS 电感	PIN(1-4)	10.0mH MIN.	F(kHz) =70 Ug(V) =1	SERIAL MODE 串联模式
DCR 直流 电阻	PIN(1-4)	2.6Ω MAX.	/	4 WIRE MODE 四线模式
	PIN(7-9)	5.2mΩ MAX.	/	4 WIRE MODE 四线模式
	PIN(10-12)	8.6mΩ MAX.	/	4 WIRE MODE 四线模式
HIPOT 耐压	PRI./SEC.	NO BREAKDOWN 漏电流≤2.0mA	VAC=3750V/2SEC. F(Hz)=60	
	PRI./CORE	NO BREAKDOWN 漏电流≤2.0mA	VAC=2000V/2SEC. F(Hz)=60	
	SEC./CORE	NO BREAKDOWN 漏电流≤2.0mA	VAC=2000V/2SEC. F(Hz)=60	
IR 绝缘电阻	COIL/COIL	100MΩ MIN.	DC500V	
	COIL/CORE	100MΩ MIN.	DC500V	
PH 相位	REFER TO LAYOUT DIAGRAM (FIG-1) 参考原理图 (FIG-1)			

Prepared By ENG:	DATE :	TITLE: TRANSFORMER	CUSTOMER Approved:	MODEL NO:EER28	
Checked By QA:	DATE:			REV.:	00
Approved By ENG:	DATE:			PAGE 1 OF 3	



OUTLINE DIAGRAM (外观图) :

UNIT : mm

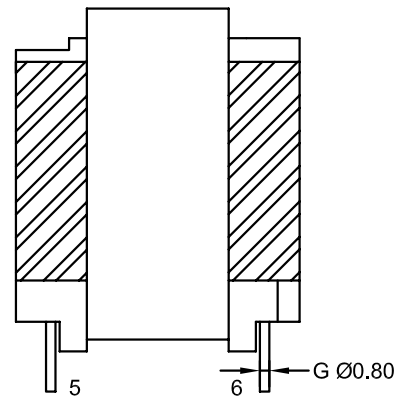
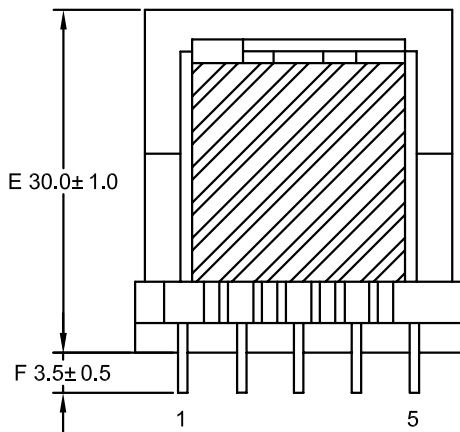
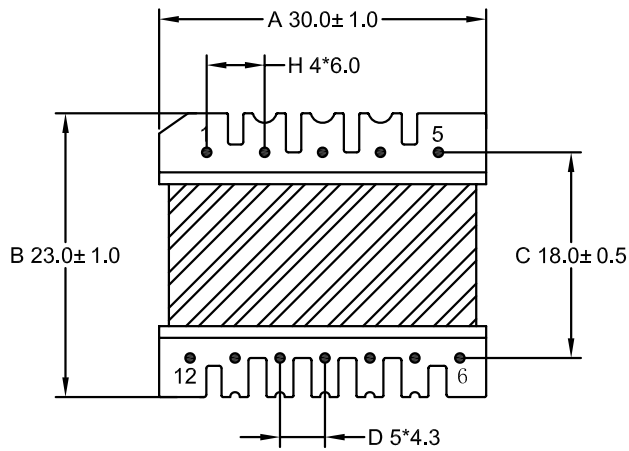

NOTE:

1. Assembly the 2 magnetic cores on the bobbin with 2 layers 11.5mm width tape .
用2层11.5mm宽的胶带将两铁芯组装在胶芯上.
2. The product must be impregnated vanish.
产品须含浸凡立水.
3. YYWW:year week code;
YYWW 年份周期代码;
4. The product should be according to RoHS
产品要符合RoHS

Prepared By ENG:	Date :	TITLE : TRANSFORMER	CUSTOMER Approved: Date:	MODEL NO. :EER28		
Checked By QA:	Date :			REV. :	00	
Approved By ENG:	Date :			PAGE 2 OF 3		



LAYOUT DIAGRAM(原理圖) : (FIG-1)

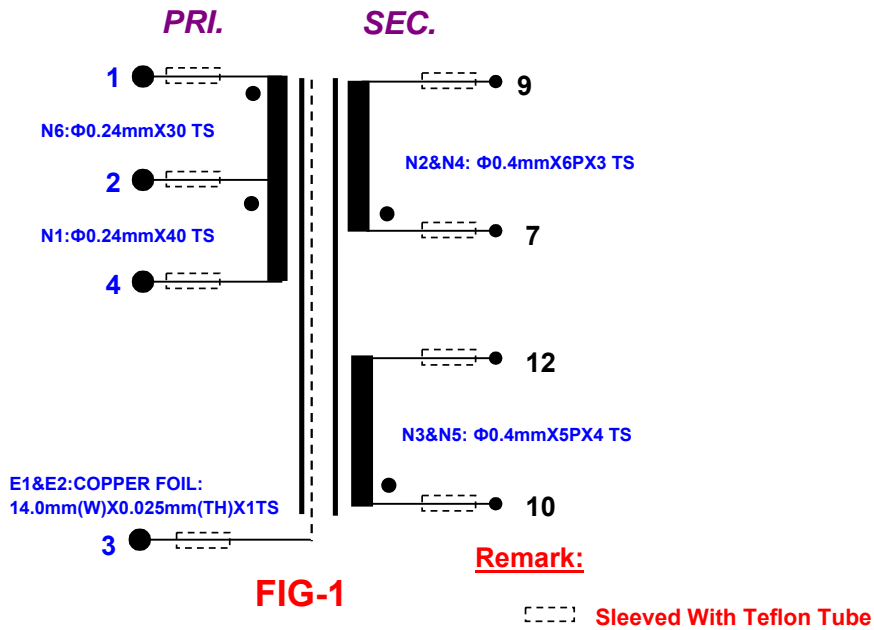

CROSS SECTION DIAGRAM剖视图 : (FIG-2)

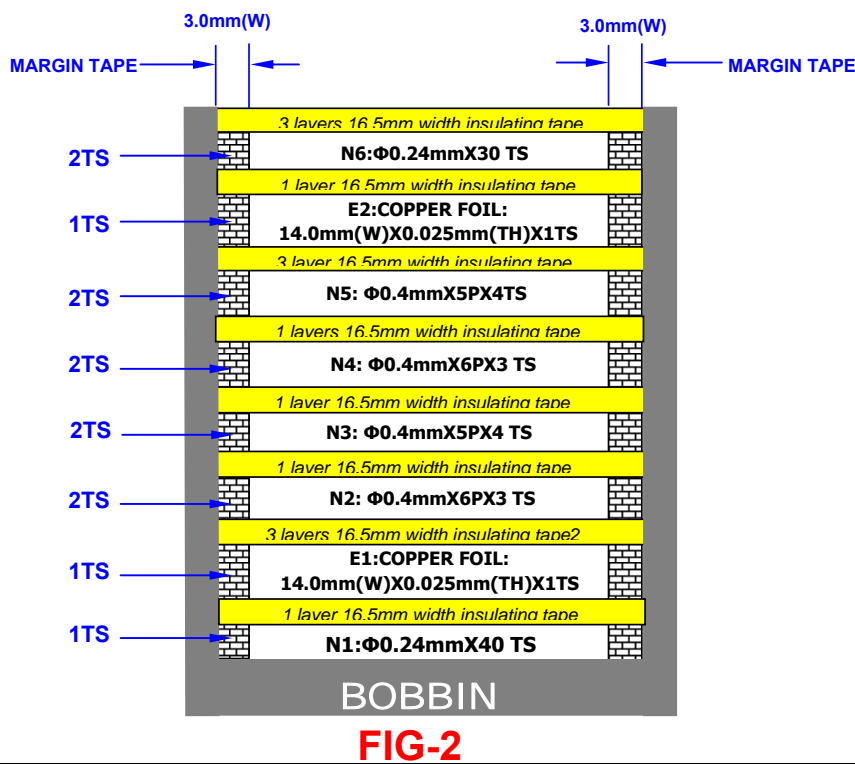

Prepared By ENG:	DATE :	TITLE: TRANSFORMER	CUSTOMER	MODEL NO:EER28		
Checked By QA:	DATE :			Approved:	REV.	00
Approved By ENG:	DATE :			Date:	PAGE 3 OF 3	

免责声明
Disclaimer

Specifications and appearances may change without notice. All statements, technical information and recommendations herein are based on tests that we believed to be reliable, but the accuracy and completeness are not guaranteed. Before using, user should determine the suitability of the product for its intended use, and the user assumes all risks and liabilities whatsoever in connection therewith. Neither the seller nor the manufacturer shall be liable for any loss or damage, direct, incidental or consequential, including loss of profits or revenues arising from the use or inability to use the product. Any statements or recommendations shall have no effect unless contained in an agreement signed by authorized personnel of the seller and manufacturer.

依美电感保留更改产品资料和外观的最终权利而无需事先通知。如有任何争议，依美电感保留最终决定权。此中文免责声明为英文版本译本，如中、英文两个版本有任何抵触或不相符之处，应以英文版本为准。