



DATA SPECIFICATION (特性要求) : (Table-1)

ITEM 項目	MEASUREMENTS 测试脚位	CHARACTERISTICS 测试範圍	MEASURING CONDITIONS 测试條件 T(°C)=25±3; HR(%)=45 +15	REMARK 備注
LS 电感	PIN(4-1)	0.95mH±15%	F(KHz) =10 Ug(V) =0.1	SERIAL MODE 串联模式
LK 漏感	PIN(4-1)	40uH MAX.	F(KHz) =100 Ug(V) =0.1 short pin6&10	SERIAL MODE 串联模式
DCR 直流 电阻	PIN(4-1)	600mΩ MAX.	/	4WIRE MODE 四线模式
	PIN(6-10)	130mΩ MAX.	/	4WIRE MODE 四线模式
HIPOT 耐压	(4-1)/(6-10)	NO Breakdown 漏电流 ≤5.0mA	VAC=3750V /1SEC. F(Hz) =50Hz	/
	(4-1), (6-10)/CORE	NO Breakdown 漏电流 ≤5.0mA	VAC=2000V /1SEC. F(Hz) =50Hz	/
TR 圈比	(4-1)/(6-10)	75:16±0.3TS	F(KHz) =10 Ug(V) =1	Apply Ug(4-1) 电压施加于(4-1)
PH 相位	REFER TO LAYOUT DIAGRAM(FIG-1) 参考原理图 (FIG-1)			

Prepared By ENG:	DATE:	TITLE: TRANSFORMER	CUSTOMER	MODEL NO:EEL25	
Checked By QA:	DATE:		Approved:	REV.	00
Approved By ENG:	DATE:		Date:	PAGE 1 OF 3	



OUTLINE DIAGRAM (外观图) :

UNIT : mm

TOLERANCE: .X ± 0.5 .XX ± 0.1

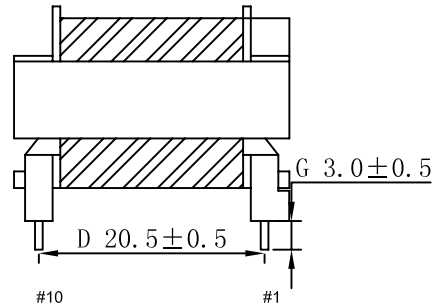
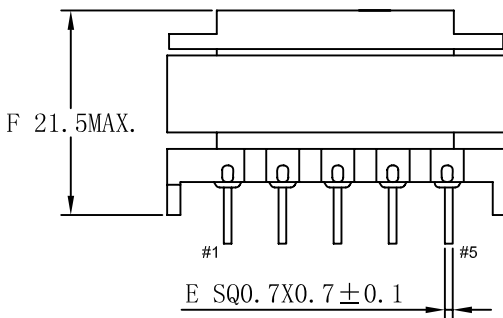
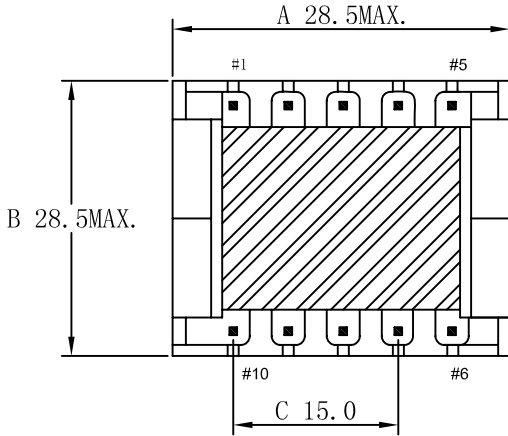

NOTES:

1. The product must be impregnated varnish #642.
产品须含浸凡立水#642.
2. The core are to be held with 2 layers 7.2mm width tape;
在铁芯上包2 圈7.2mm宽的胶纸;
3. YYWW: year and week code (FIG-4).
YYWW: 年份周期代码 (FIG-4).
4. the part should be complied with RoHS requirement.
产品需符合ROHS要求.

Prepared By ENG:	Date :	TITLE : TRANSFORMER	CUSTOMER Approved: Date:	MODEL NO. : EEL25	
Checked By QA:	Date :			REV. :	00
Approved By ENG:	Date :			PAGE 2 OF 3	



LAYOUT DIAGRAM (原理圖) : (FIG-1)

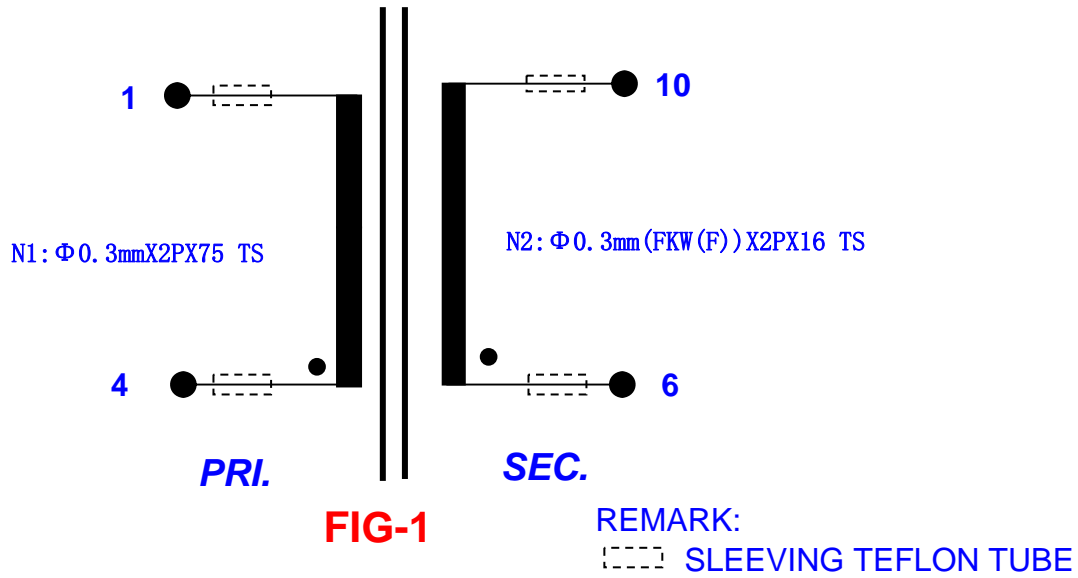

CROSS SECTION DAGRAM剖视图: (FIG-2)

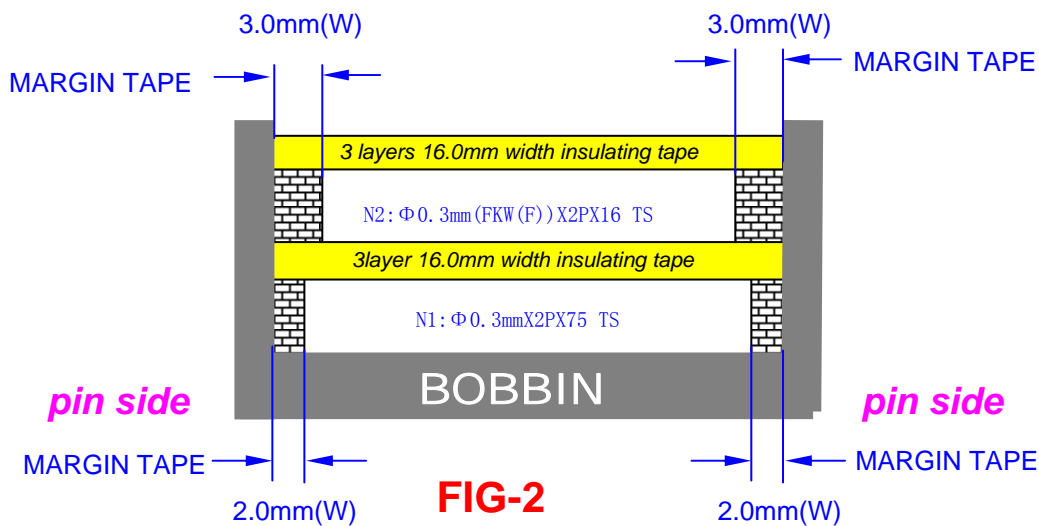

Prepared By ENG:	DATE:	TITLE: TRANSFORMER	CUSTOMER	MODEL NO: EEL25	
Checked By QA:	DATE:		Approved:	REV.	00
Approved By ENG:	DATE:		Date:	PAGE 3 OF 3	

免责声明 Disclaimer

Specifications and appearances may change without notice. All statements, technical information and recommendations herein are based on tests that we believed to be reliable, but the accuracy and completeness are not guaranteed. Before using, user should determine the suitability of the product for its intended use, and the user assumes all risks and liabilities whatsoever in connection therewith. Neither the seller nor the manufacturer shall be liable for any loss or damage, direct, incidental or consequential, including loss of profits or revenues arising from the use or inability to use the product. Any statements or recommendations shall have no effect unless contained in an agreement signed by authorized personnel of the seller and manufacturer.

依美电感保留更改产品资料和外观的最终权利而无需事先通知。如有任何争议，依美电感保留最终决定权。此中文免责声明为英文版本译本，如中、英文两个版本有任何抵触或不相符之处，应以英文版本为准。